



PROPERTY PLAT FOR:
LINKER-PORTAGE DITCH
 LOCATED IN SECTIONS 16, 17, & 20,
 T6N, R14E, HARRIS TOWNSHIP,
 OTTAWA COUNTY, OHIO
 2022

INDEX OF SHEETS



PROPERTY PLAT _____	1
PROPERTY PLAT INDEX _____	2

LEGEND:

-  WATERSHED BOUNDARY
-  SURFACE DRAINAGE IN WATERSHED;
SUBSURFACE DRAINAGE EXITING WATERSHED (TILE OUT)

I HEREBY APPROVE THIS PLAT.

RONALD P. LAJTI, JR., P.E., P.S. _____ DATE _____
 OTTAWA COUNTY ENGINEER

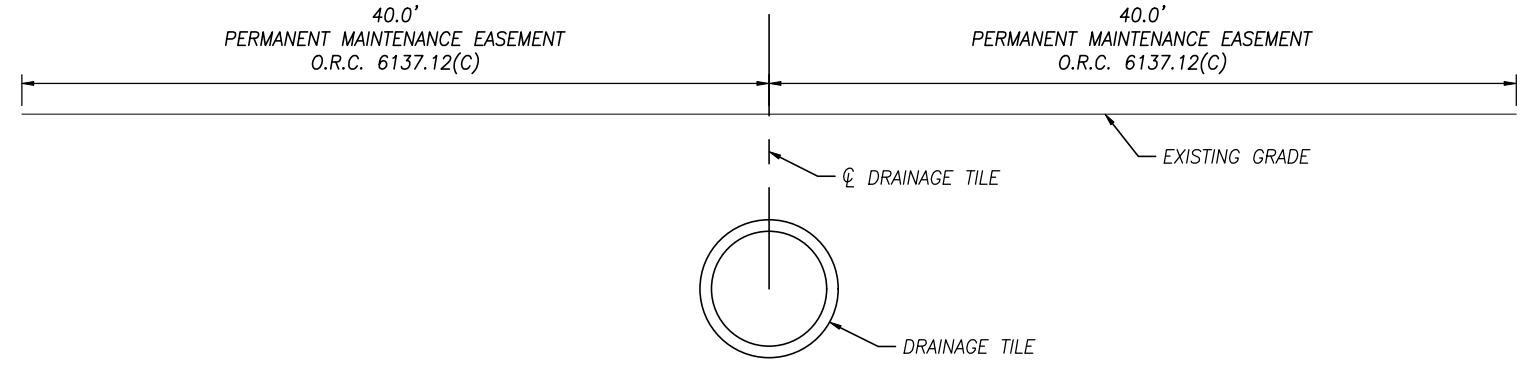
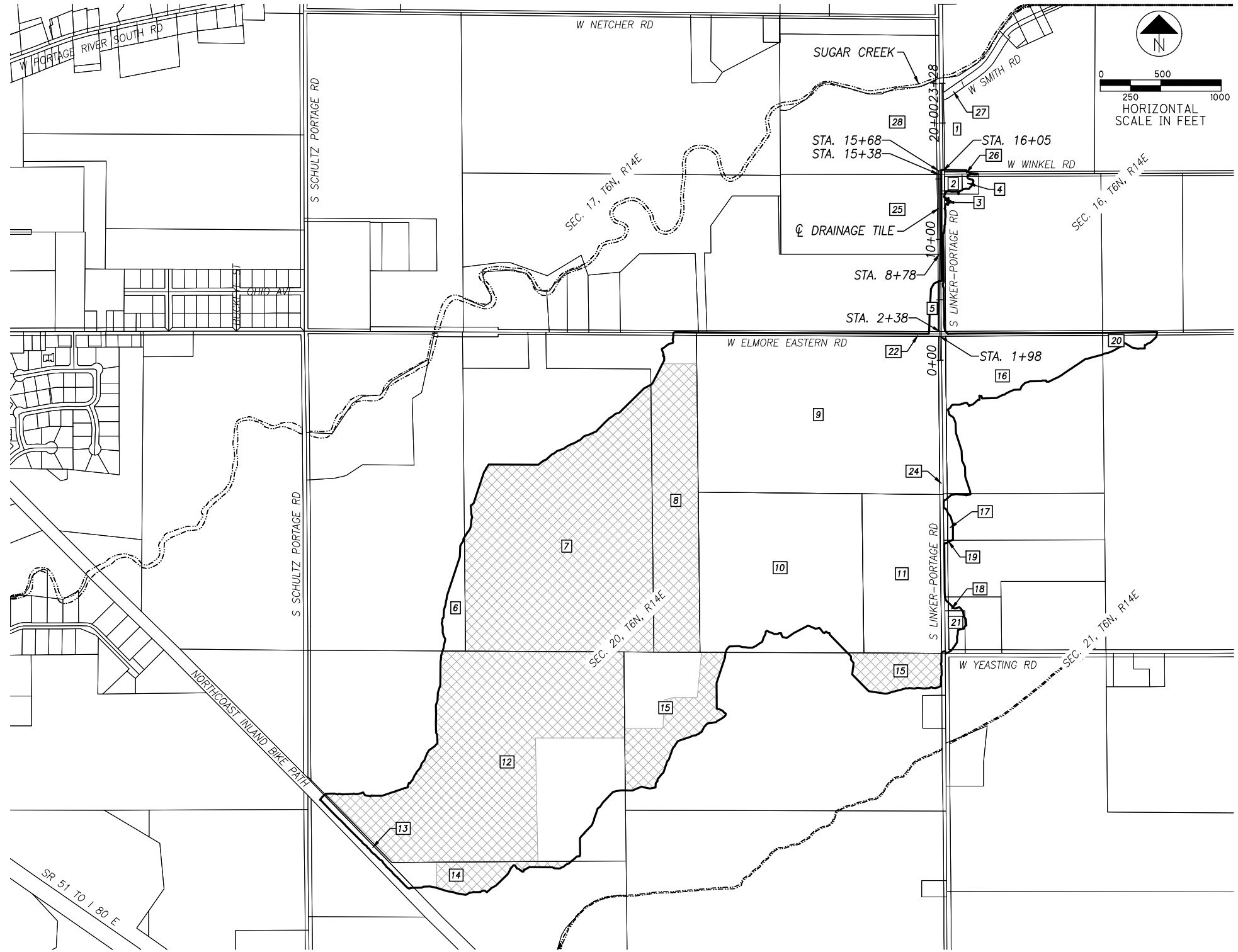

TYPICAL DRAINAGE IMPROVEMENT SECTION - CLOSED DITCH

S:\Ditches\Linker Portage Ditch\21-019 Linker Portage Ditch 6-year Review\21-019 Linker Portage - CAD\21-019 LinkerPortage_PlatMap.dwg 07-Jul-22 1:43 PM

PROJECT NO. **OCE 21-019**
 OCE DITCH NO. **3**
 OSWCD DITCH NO. **-**
 AUDITOR DITCH NO. **11-148**

LINKER-PORTAGE DITCH
 1
 2

PLAT REF. NO.	OWNER	R	T	S	PARCEL NUMBER	PROPERTY TYPE	DRAINAGE TYPE	ACRES OWNED	ACRES BENEFITED	PERMANENT MAINTENANCE EASEMENT (OD=OPEN DITCH) (CD=CLOSED DITCH)	10' PERMANENT EASEMENT SEEDING/SOD STRIP ACRES (O.R.C. 6131.14)
		14	6	16	HARRIS TOWNSHIP						
1	NETCHER FAMILY RENTALS LLC	14	6	16	017-05128-06587-000	AG	Surface	33.421	0.058	CD	N/A
2	THOMAS F & IRENE L MILLER	14	6	16	017-07347-17197-000	RES	Surface	0.49	0.395		
3	JANICE NETCHER	14	6	16	017-05128-06581-000	AG	Surface	39.15	0.051		
4	THOMAS F & IRENE L MILLER	14	6	16	017-05128-06581-001	RES	Surface	0.624	0.197		
25	GEN 7 FARMS LLC	14	6	16	017-05482-25292-002	AG	-	20.018	0	CD	N/A
28	DAVID F NETCHER	14	6	16	017-05482-25292-001	AG	-	20.85	0	CD	N/A
		14	6	17	HARRIS TOWNSHIP						
5	ANDREW FOX	14	6	17	017-05164-06622-000	AG	Surface	35.02	0.62	CD	N/A
		14	6	20	HARRIS TOWNSHIP						
6	ROBERT R & KATHLEEN A BENCH	14	6	20	017-05186-06651-001	AG	Surface	54.431	2.661		
7	KNIPP FARMS INC	14	6	20	017-05176-06650-000	AG	Tile Out	84.999	60.577		
8	GARRY H & DEBBIE J KNIPP	14	6	20	017-05176-06637-000	AG	Surface	29.062	1.352		
						AG	Tile Out	29.062	20.69		
9	MELVIN H & DIANE M GIESLER	14	6	20	017-05171-06631-000	AG	Surface	60	59.787	CD	N/A
10	RICHARD BLAUSEY & SHARON ELDER	14	6	20	017-05174-06635-000	AG	Surface	41	38.299		
11	RICHARD BLAUSEY & SHARON ELDER	14	6	20	017-05174-06640-000	AG	Surface	20	19.417		
12	BENCH ELMORE FARMS LLC	14	6	20	017-01629-29957-000	AG	Surface	98.982	14.118		
						AG	Tile Out	98.982	54.51		
13	VILLAGE OF ELMORE	14	6	20	019-00001-00004-000	AG	Surface	13.58	1.084		
14	KURT & CORINNA BENCH	14	6	20	017-05184-06648-001	AG	Surface	25.173	1.66		
						AG	Tile Out	25.173	3.682		
15	ROBERT BENCH	14	6	20	017-05179-06642-000	AG	Surface	78.803	7.26		
						AG	Tile Out	78.803	13.446		
		14	6	21	HARRIS TOWNSHIP						
16	KINNEY LITTLEFIELD	14	6	21	017-05206-06675-000	AG	Surface	40	13.905		
17	CHARLES L & DEBORAH S HERMAN	14	6	21	017-05197-06663-000	AG	Surface	11.794	0.247		
18	NICOLE K HARR	14	6	21	017-05201-06670-000	RES	Surface	3.671	0.091		
19	JOHN A & JULIE M BERGMAN	14	6	21	017-05197-06666-000	AG	Surface	11.794	0.007		
20	ROSEMARIE BENCH	14	6	21	017-18788-25215-000	AG	Surface	140	1.001		
21	NICOLE K HARR	14	6	21	017-05201-06670-001	RES	Surface	1.336	0.702		
					HARRIS TOWNSHIP						
22	OTTAWA COUNTY ENGINEER - ELMORE EASTERN RD				017-19116-00001-000	R/W	Surface	-	2.105	CD	N/A
23	HARRIS TOWNSHIP TRUSTEES - LINKER PORTAGE RD				017-19095-25841-000	R/W	Surface	-	0.879	CD	N/A
24	HARRIS TOWNSHIP TRUSTEES - LINKER PORTAGE RD				017-19095-25841-000	R/W	Surface	-	3.264	CD	N/A
26	HARRIS TOWNSHIP TRUSTEES - WINKEL RD				017-19095-25841-000	R/W	Surface	-	0.194		
27	HARRIS TOWNSHIP TRUSTEES - SMITH RD				017-19095-25841-000	R/W	-	-	0	CD	N/A